



Residential Generator Installation Requirements

Skamania County Building Department
PO Box 1009
Stevenson, WA 98648
(509) 427-3925
building@co.skamania.wa.us

Documentation needed for application:

1. A site plan showing the location of the generator on the lot and its distance to:
 - Combustible material such as structures and vegetation
 - Openings into the home including doors, operable windows, and vents
 - Other equipment such as air conditioners, heat pumps, and gas meters
 - Property lines, sidewalks, and streets
2. Indicate the type of fuel to be supplied and the location of any gas lines or tanks.
3. Specify the type of base that will be provided and how the unit will be anchored.

Other considerations:

1. If your property is included in a Covenants, Conditions & Restrictions (CC&R) document that has been recorded with the County, it is recommended to read those thoroughly to ensure there are not any further restrictions for a generator.
2. An electrical permit is also required from Washington State Labor and Industries.
3. The generator must be approved by the manufacturer for its intended application and use and installed according to the installation instructions.
4. Residential generators must comply with zoning setbacks, which are often more restrictive than building clearance requirements. Check with a planner at permitting@co.skamania.wa.us if you are unsure of your property's setbacks.

If the manufacturer's installation instructions do not specify clearances to combustible materials, the required clearance must be 5 feet.

If the manufacturer's installation instructions do not specify clearances to openings into the house, the required clearance must be 5 feet from the opening with the generator exhaust port turned away from the openings.

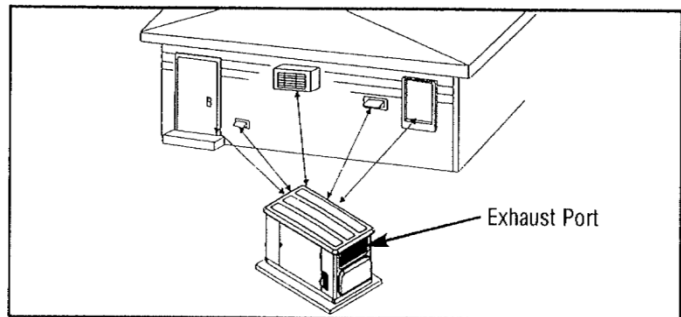

Inspection:

When requesting inspection of the completed installation, please provide:

1. The manufacturer's installation manual.
2. A minimum of 3 PSI pressure test on gas piping for a minimum of 10 minutes.
3. A listed gas connector and shut off valve for the specific application.

⚠ WARNING	
	Running engine gives off carbon monoxide, an odorless, colorless, poison gas.
	Breathing carbon monoxide can cause headache, fatigue, dizziness, vomiting, confusion, seizures, nausea, fainting or death.

- Operate generator ONLY outdoors
- Install a battery-operated carbon monoxide alarm near the bedrooms
- Keep exhaust gas from entering confined areas through windows, doors, ventilations intakes, or other openings